

2016-18 CHEVY SILVERADO 1500 HID LED RH LWR INBOARD HEADLIGHT TAB KIT P/N 25-10040

(Please visit CreativeRepairSolutions.com for detailed instruction videos.)

| KIT CONTENTS | QTY | TOOLS REQUIRED | |
|---------------------------------------|-----|------------------------|-------------------------|
| 20-10014 RH LWR INBOARD HEADLIGHT TAB | 1 | PROTECTIVE EYEWEAR | SCUFFING OR SANDING PAD |
| #8 X .625 PAN HEAD SCREW (A) | 3 | SCREW GUN OR DRILL PH1 | ALCOHOL PRE-CLEANER |
| ADHESIVE PIPETTE | 1 | CUT-OFF WHEEL | MEASURING DEVICE |
| | | DA SANDER | |

1. Trim: Using a cut-off wheel, trim the damaged tab to the **MAX** dimension whenever possible, **Fig. 1**. Make note that in this case the trimming line is both the **MIN** and **MAX** dimension, **Fig. 1**. Trim flush to the plane marked **MIN MAX**, **Fig. 2** Next, Sand rough edges to remove excess material from trimming and to ensure a proper fit.

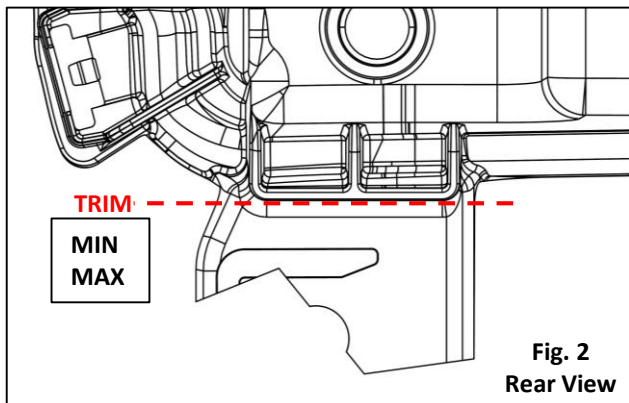
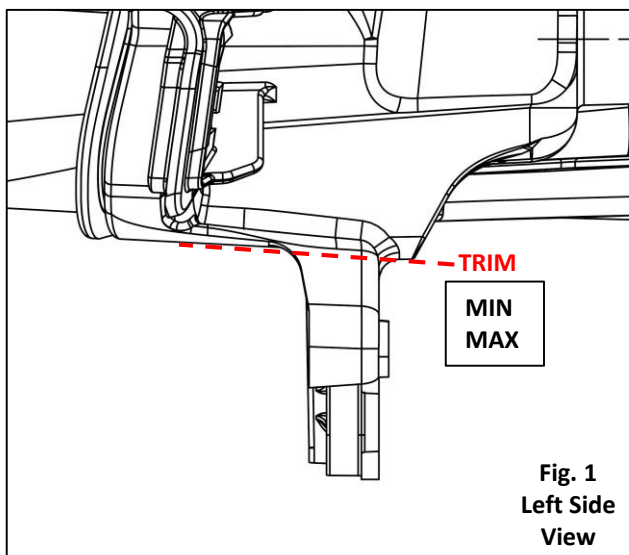

2. Dry-Fit: Dry-fit the repair tab(s) **Fig. 3**. If the tab fits without resistance and makes a flush fit to the housing, trimming is complete. If the tab resists installation re-trim the damaged tab, removing only small amounts of material. Repeat the Dry-Fit steps until the proper fit is achieved.

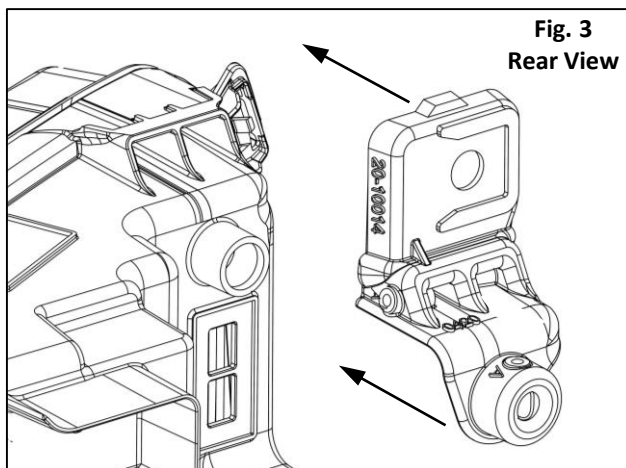

3. Scuff & Glue: Scuff the housing and tab(s) using a sanding pad. Remove sanding dust using compressed air. Wipe down the housing and tab(s) using a pre-cleaner to ensure surfaces are free from oil and debris. Apply glue to both the housing and tab(s).

4. Install: Install the prepared tab(s) ensuring a flush fit to the housing **Fig. 4**. Next, drive the 5/8" screws at the location marked **(A1)**, then at locations **(A)**. Do not overtighten the screws. Allow the glue to cure for approximately 30 minutes before installing the repaired headlight on the vehicle.

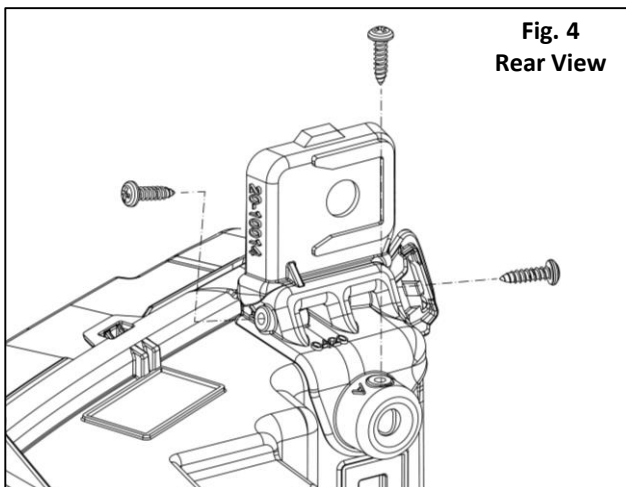

SEE REVERSE SIDE for views of properly trimmed headlamp tab.

