



2014-21 JEEP GRAND CHEROKEE RH LWR OUTBOARD HEADLIGHT TAB HID

P/N 25-10011

(Please scan the QR Code on the back of this sheet for video instructions.)

KIT CONTENTS	QTY	TOOLS REQUIRED	
19-10004 RH LWR OUTBOARD HEADLIGHT TAB	1	PROTECTIVE EYEWEAR	SCUFFING OR SANDING PAD
19-10005 RH LWR OUTBOARD HEADLIGHT TAB CVR	1	SCREW GUN OR DRILL PH1	ALCOHOL PRE-CLEANER
#8 X .625 PAN HEAD SCREW (A1) (A)	3	CUT-OFF WHEEL	MEASURING DEVICE
ADHESIVE PIPETTE	1	DA SANDER	

1. Trim: Using a cut-off wheel, trim the damaged tab to the **MAX** dimension whenever possible, **Fig. 1**. Make note of the trimming plane to which the **MAX** dimension refers, **Fig. 2**. The **MIN** indicates the least amount of material allowed for proper screw engagement. Next, Sand rough edges to remove excess material from trimming and to ensure a proper fit.

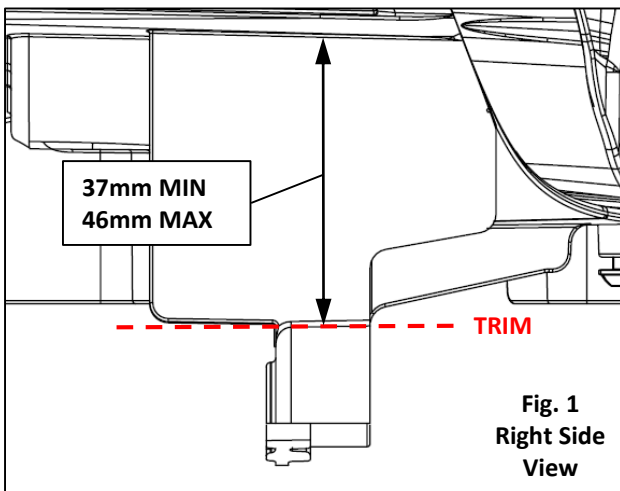

Fig. 1
Right Side View

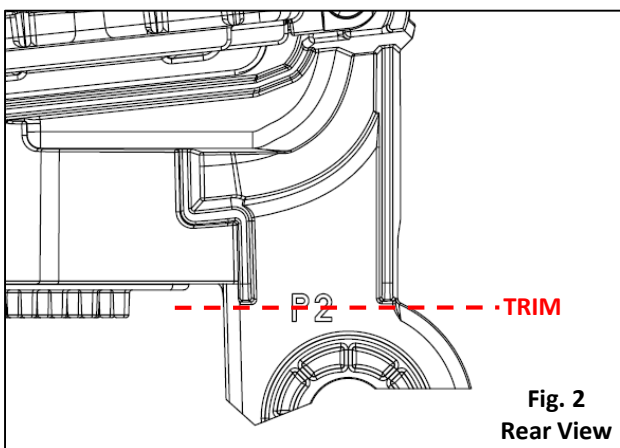

Fig. 2
Rear View

2. Dry-Fit: Dry-fit the repair tab(s) **Fig. 3**. If the tab fits without resistance and makes a flush fit to the housing, trimming is complete. If the tab resists installation re-trim the damaged tab, removing only small amounts of material. Repeat the Dry-Fit steps until the proper fit is achieved.

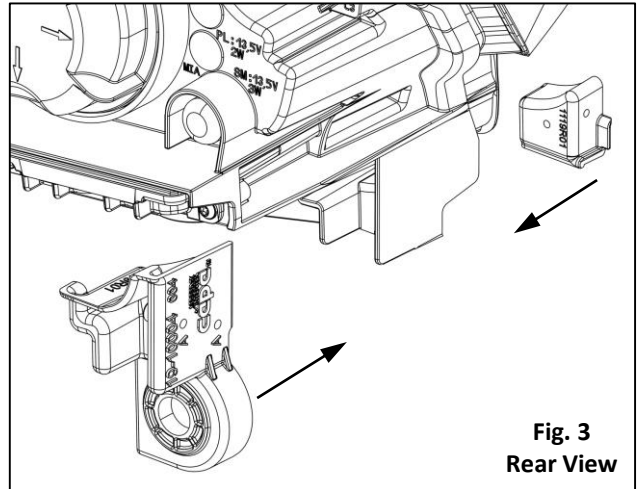

Fig. 3
Rear View

3. Scuff & Glue: Scuff the housing and tab(s) using a sanding pad. Remove sanding dust using compressed air. Wipe down the housing and tab(s) using a pre-cleaner to ensure surfaces are free from oil and debris. Apply glue to both the housing and tab(s).

4. Install: Install the prepared tab(s) ensuring a flush fit to the housing, **Fig. 4**. Next, drive the 5/8" screw at location **(A1)**. Finish by driving the two 5/8" screws at the locations marked **(A)**. Do not overtighten the screws. Allow the glue to cure for approximately 30 minutes before installing the repaired headlight on the vehicle.

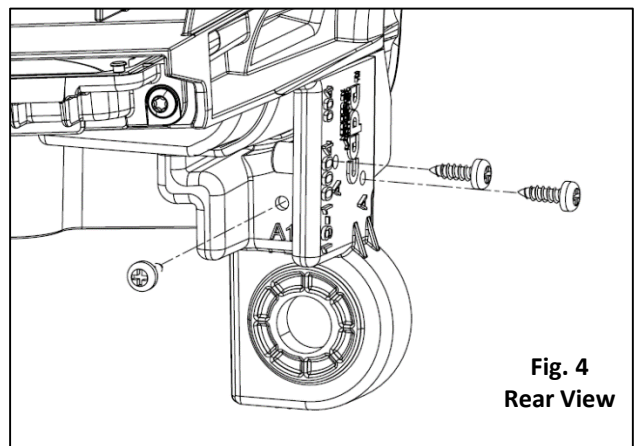

Fig. 4
Rear View

SEE REVERSE SIDE for views of properly trimmed headlamp tab.

WATCH HOW-TO VIDEO →

