



F150 RH UPR MID HEADLIGHT TAB HAL P/N 25-10126

KIT CONTENTS	QTY	TOOLS REQUIRED	
18-10043 RH UPR MID HEADLIGHT TAB HAL	1	PROTECTIVE EYEWEAR	SCUFFING OR SANDING PAD
18-10044 RH UPR MID HEADLIGHT TAB INSERT HAL	1	SCREWDRIVER - PH1	ALCOHOL PRE-CLEANER
#8 X .625 PAN HEAD SCREW (A)	3	CUT-OFF WHEEL	MEASURING DEVICE
ADHESIVE PIPETTE	1	DA SANDER	

1. Trim: Using a cut-off wheel, trim the damaged tab to the **MAX** dimension whenever possible, **Fig. 1**. Make note of the trimming plane to which the **MAX** dimension refers, **Fig. 2**. The **MIN** indicates the least amount of material allowed for proper screw engagement. Next, Sand rough edges to remove excess material from trimming and to ensure a proper fit.

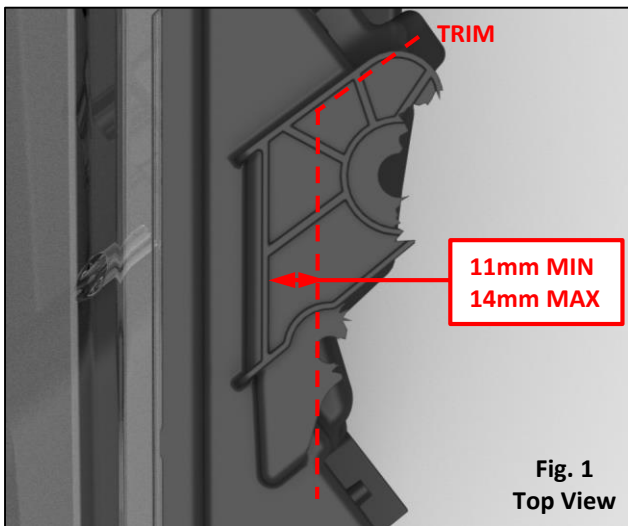

Fig. 1
Top View

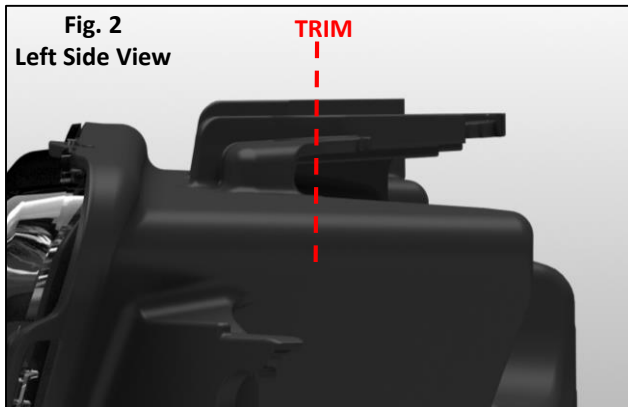

Fig. 2
Left Side View

2. Dry-Fit: Dry-fit the repair tab(s) **Fig. 3**. If the tab fits without resistance and makes a flush fit to the housing, trimming is complete. If the tab resists installation re-trim the damaged tab, removing only small amounts of material. Repeat the Dry-Fit steps until the proper fit is achieved.

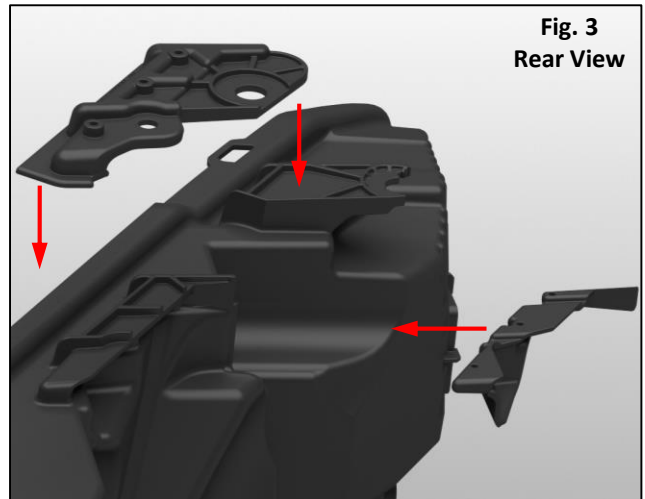

Fig. 3
Rear View

3. Scuff & Glue: Scuff the housing and tab(s) using a sanding pad. Remove sanding dust using compressed air. Wipe down the housing and tab(s) using a pre-cleaner to ensure surfaces are free from oil and debris. Apply glue to both the housing and tab(s).

4. Install: Install the prepared tab(s) ensuring a flush fit to the housing **Fig. 4**. Next, drive the 5/8" screws at the locations marked (A), while holding parts firmly together. **APPLY GLUE TO SCREW THREADS BEFORE DRIVING.** Do not overtighten screws. Allow the glue to cure for approximately 30 minutes before installing the repaired headlight on the vehicle.

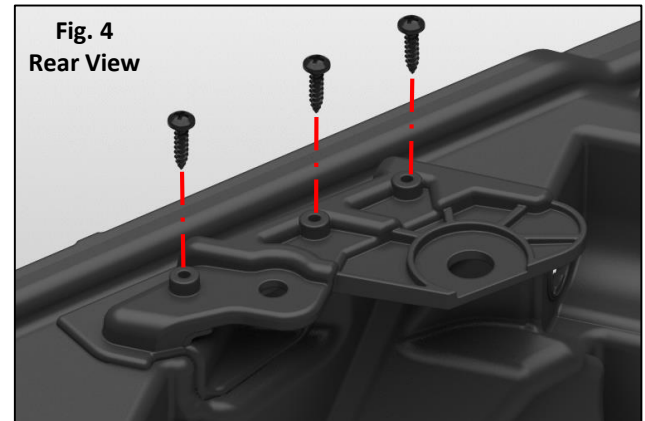

Fig. 4
Rear View

SEE REVERSE SIDE for views of properly trimmed headlamp tab.

WATCH HOW-TO VIDEO →

