



CHARGER RH LWR INBOARD HEADLIGHT TAB P/N 25-10137

(Please scan the QR Code on the back of this sheet for video instructions.)

KIT CONTENTS	QTY	TOOLS REQUIRED	
19-10013 RH LWR INBOARD HEADLIGHT TAB	1	PROTECTIVE EYEWEAR	SCUFFING OR SANDING PAD
#8 X .625 PAN HEAD SCREW (A1) (A)	4	SCREWDRIVER - PH1	ALCOHOL PRE-CLEANER
ADHESIVE PIPETTE	1	CUT-OFF WHEEL	MEASURING DEVICE
		DA SANDER	MARKING PENCIL

1. Trim: Remove the Headlamp Assembly Bracket before trimming. Using a cut-off wheel, trim the damaged tab to the **MAX** dimension whenever possible, **Fig. 1**. Make note of the trimming plane to which the **MAX** dimension refers, **Fig. 2**. The **MIN**(if present) indicates the least amount of material allowed for proper screw engagement. Next, Sand rough edges to remove excess material from trimming and to ensure a proper fit.

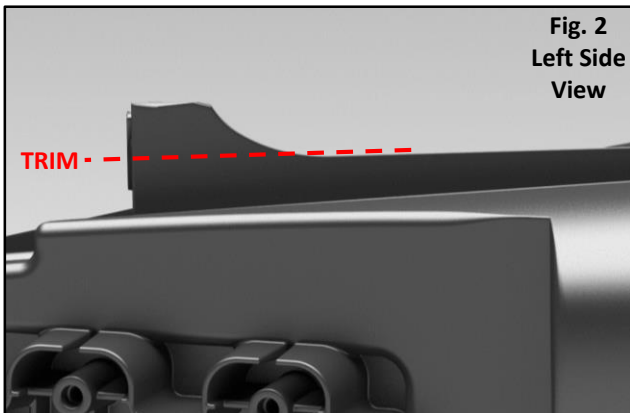
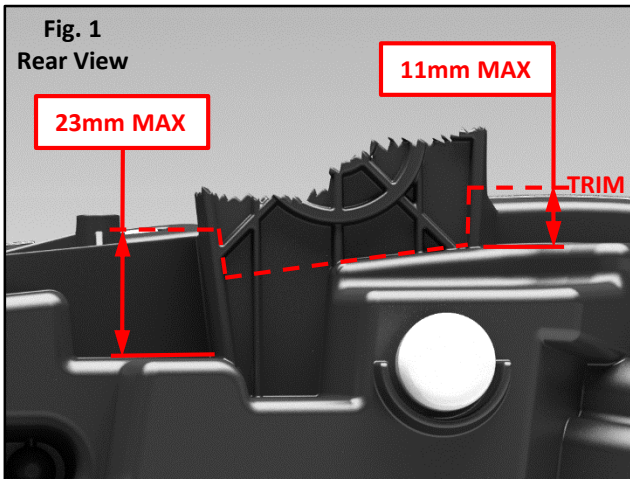

2. Dry-Fit: Dry-fit the repair tab(s) **Fig. 3**. If the tab fits without resistance and makes a flush fit to the housing, trimming is complete. If the tab resists installation re-trim the damaged tab, removing only small amounts of material. Repeat the Dry-Fit steps until the proper fit is achieved.

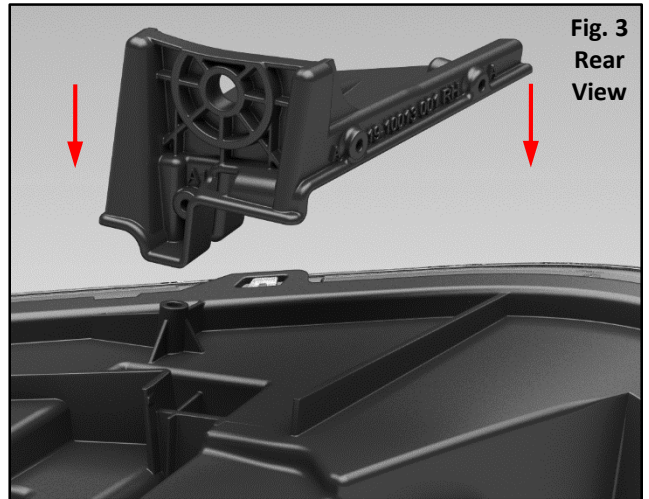

3. Scuff & Glue: Scuff the housing and tab(s) using a sanding pad. Remove sanding dust using compressed air. Wipe down the housing and tab(s) using a pre-cleaner to ensure surfaces are free from oil and debris. Apply glue to both the housing and tab(s).

4. Install: Install the prepared tab(s) ensuring a flush fit to the housing **Fig. 4**. Next, drive the 5/8" screws at the locations marked (A1). Followed by locations marked (A). **DRIVE SCREWS MANUALLY. APPLY GLUE TO SCREW THREADS BEFORE DRIVING.** Do not overtighten screws. Allow the glue to cure for approximately 30 minutes before installing the repaired headlight on the vehicle.

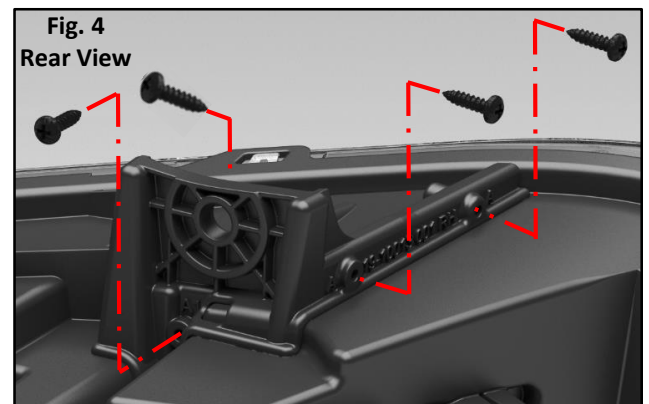

SEE REVERSE SIDE for views of properly trimmed headlamp tab.

WATCH HOW-TO VIDEO →

